

" GROUND SUPPORT VEHICLES, BAGGAGE CARTS AND CONVEYOR SYSTEMS "

Carson Flight Fend Bumpers, originally designed for marine use, have been utilized by airlines, and manufacturers of motorized vehicles, baggage carts and conveyor systems for over 20 years.

- ◀ Pneumatic structure provides protective cushion
- ◀ Specially formulated vinyl
- ◀ Color is an integral part of the bumper and will not transfer
- ◀ Minimum of maintenance
- ◀ Recessed mounting locations provide secure attachment
- ◀ UV stabilizers prevent discoloration and stiffening
- ◀ Highly resistant to corrosion, abrasion and most chemicals
- ◀ Available in white or yellow



311 - CORNER BUMPER

The 311 Corner Bumper is the foundation of our Ground Support Equipment and safety bumper line. This is the original workhorse designed to protect aircraft from accidental damage from equipment. Over the years, GSE personnel have found the 311 to control safety issues in other areas of maintenance.

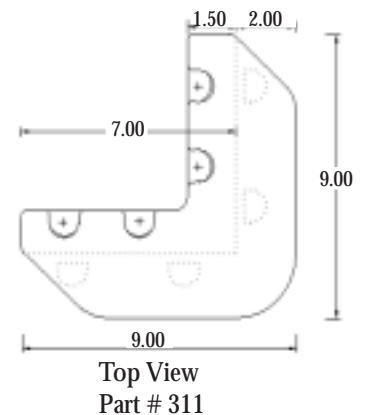

311LS - TAPERED CORNER BUMPER

The 311LS Tapered Corner Bumper is our 311 redesigned with a tapered profile. A reduced angle from the apex to the leading edge decreases the likelihood of accidental shearing.

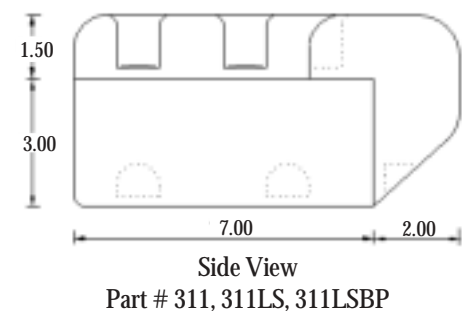

311LSBP - TAPERED BACKING PLATE CORNER BUMPER

The 311LSBP incorporates a metal backing plate into our tapered design, adding increased strength and stability and virtually eliminates the potential for accidental shearing. The metal backing plate made of corrosion resistant 16 gauge-galvanized steel is molded directly into the bumper. The material compound has been reformulated to a slightly harder durometer to withstand punctures. The 311LSBP is vented to absorb any impact. It comes with holes already pre-drilled for quick, easy, and secure mounting.

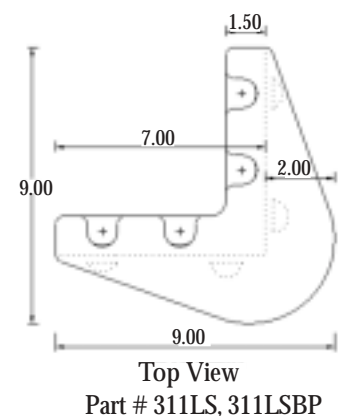



321 - STRAIGHT BUMPER

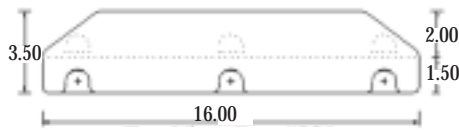

Top View Part # 321

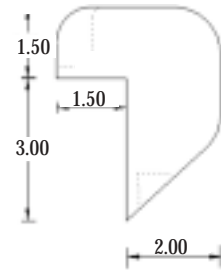

End View Part # 321

The 321 Straight Bumper is useful on conveyer systems in protecting packages and personnel, and a companion to the corner bumper.



421 - FLAT BUMPER

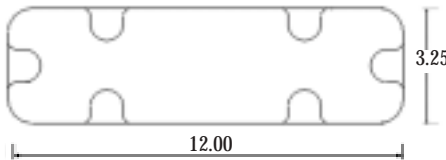

Top View Part # 421

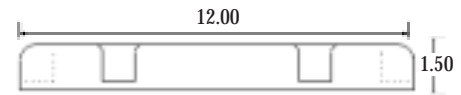

Side View Part # 421

The 421 Flat Bumper is similar to our 321 Straight Bumper but without a top lip (please refer to drawings for dimension detail.) It is designed specifically to cover flat surface areas.



441 - END BUMPER

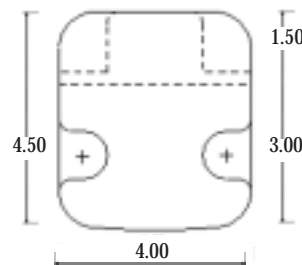

Top View Part # 441

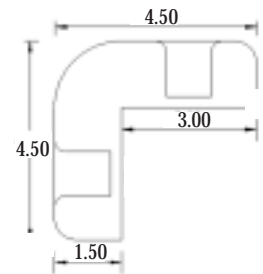

Side View Part # 441

The 441 End Bumper was originally designed for use on transverse conveyer ends. Our customers have found it extremely useful in cushioning low overhead, knee and leg obstructions due to softer material formulation.